

# CSC421/2516 Lecture 4: Convolutional Neural Networks & Image Classification

Jimmy Ba and Bo Wang

- a.k.a. How do computers **see** the world?

# Logistics

Some administrative stuff:

- HW 2 is out! (Due Feb 24!)
- HW1 is due Feb 3!
- Final Project
  - The project guideline is released!
  - Having trouble forming a team? send us an email!
- Midterm
  - The midterm quiz will cover the lecture materials up to lecture 4.
  - Date: 24 hours, Feb 09, only for undergrad students
  - Marking Scheme: You have two attempts on Quercus and we take the best score only.
  - Time conflict? send us an email!

# Overview

So far in the course, we've seen two types of layers:

- fully connected layers (Lecture 2)
- embedding layers (i.e. lookup tables) (Lecture 3)

Different layers could be stacked together to build powerful models.

Let's add another layer type: **convolution layers**

Conv layers are very useful building blocks for computer vision applications.



Layers



Optimization



# A brief history

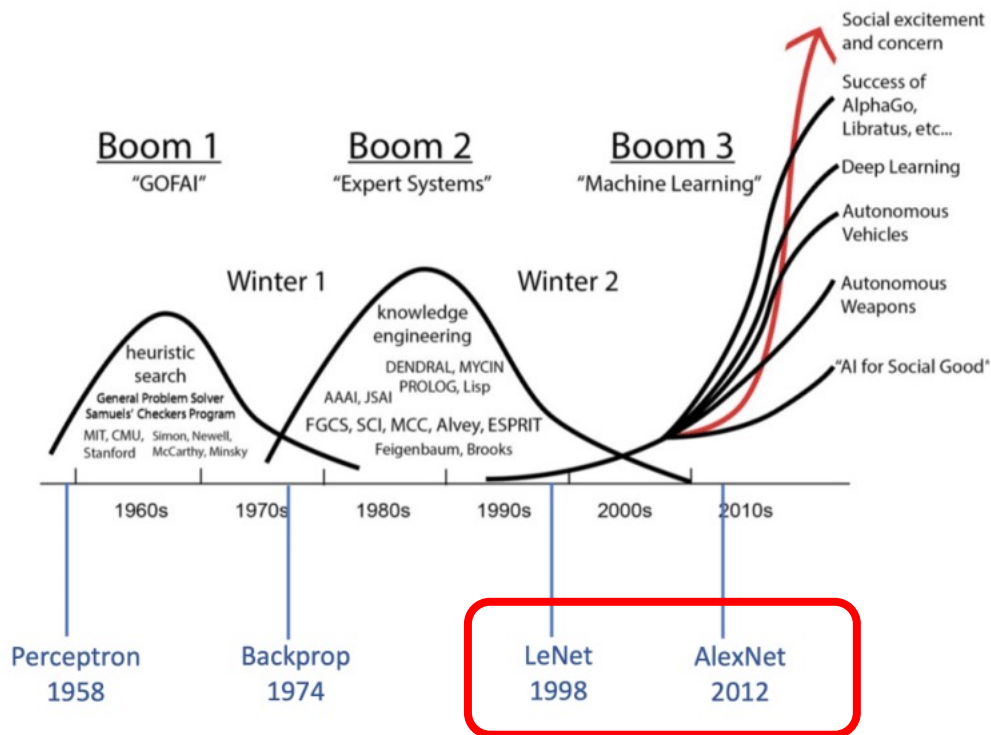

# How do we teach computers vision?

## What makes vision hard?

- Vision needs to be robust to a lot of transformations or distortions:
  - change in pose/viewpoint
  - change in illumination
  - deformation
  - occlusion (some objects are hidden behind others)
- Many object categories can vary wildly in appearance (e.g. chairs)
- Geoff Hinton: “Imaging a medical database in which the age of the patient sometimes hops to the input dimension which normally codes for weight!”

# How do we teach computers vision?

What will you do before this lecture?

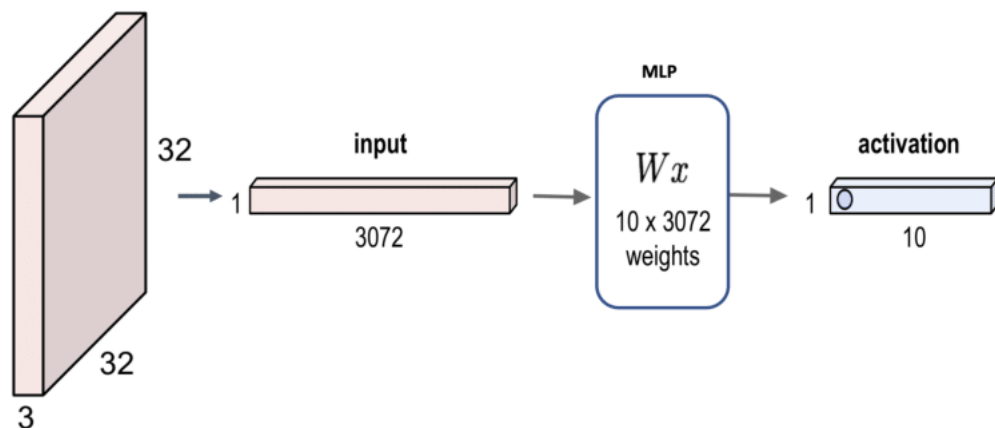

This isn't going to scale to full-sized images.

## How do we teach computers vision?

Suppose we want to train a network that takes a  $200 \times 200$  RGB image as input.

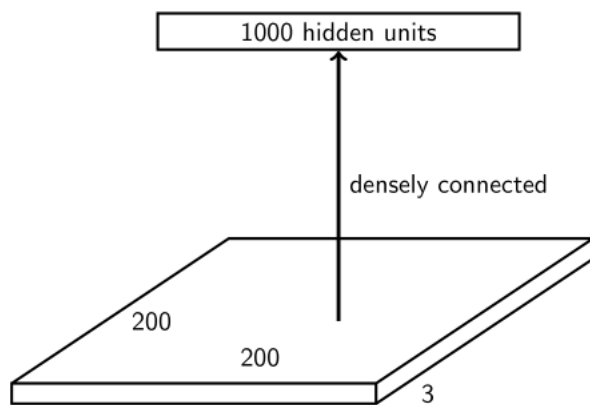

What is the problem with having this as the first layer?

- Too many parameters! Input size =  $200 \times 200 \times 3 = 120\text{K}$ . Parameters =  $120\text{K} \times 1000 = 120$  million.
- What happens if the object in the image shifts a little?

# How do we teach computers vision?

In the fully connected layer, each feature (hidden unit) looks at the **entire image**. Since the image is a **BIG** thing, we end up with lots of parameters.

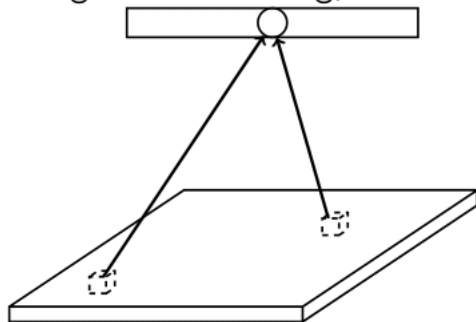

But, do we really expect to learn a useful feature at the first layer which depends on pixels that are spatially far away ?

The far away pixels will probably belong to completely different objects (or object sub-parts). Very little correlation.

We want the incoming weights to focus on **local** patterns of the input image.



# How do we teach computers vision?

The same sorts of features that are useful in analyzing one part of the image will probably be useful for analyzing other parts as well.

E.g., edges, corners, contours, object parts

We want a neural net architecture that lets us learn a set of feature detectors **shared** at all image locations.

## A brief review: Convolution

We've already been vectorizing our computations by expressing them in terms of matrix and vector operations.

Now we'll introduce a new high-level operation, **convolution**. Here the motivation isn't computational efficiency — we'll see more efficient ways to do the computations later. Rather, the motivation is to get some understanding of what convolution layers can do.

## A brief review: Convolution

We've already been vectorizing our computations by expressing them in terms of matrix and vector operations.

Now we'll introduce a new high-level operation, **convolution**. Here the motivation isn't computational efficiency — we'll see more efficient ways to do the computations later. Rather, the motivation is to get some understanding of what convolution layers can do.

Let's look at the 1-D case first. If  $a$  and  $b$  are two arrays,

$$(a * b)_t = \sum_{\tau} a_{\tau} b_{t-\tau}.$$

Note: indexing conventions are inconsistent. We'll explain them in each case.

## A brief review: 2-D Convolution

2-D convolution is defined analogously to 1-D convolution.

If  $A$  and  $B$  are two 2-D arrays, then:

$$(A * B)_{ij} = \sum_s \sum_t A_{st} B_{i-s, j-t}.$$

# Convolution

Some properties of convolution:

- Commutativity

$$a * b = b * a$$

- Linearity

$$a * (\lambda_1 b + \lambda_2 c) = \lambda_1 a * b + \lambda_2 a * c$$

# A brief review: 2-D Convolution

## Flip-and-Filter

1	3	1
0	-1	1
2	2	-1

 \* 

1	2
0	-1

1	3	1
0	-1	1
2	2	-1

 × 

-1	0
2	1

1	5	7	2
0	-2	-4	1
2	6	4	-3
0	-2	-2	1

## Apply convolutions on images

The thing we convolve by is called a **kernel**, or **filter**.

What does this convolution kernel do?



\*

0	1	0
1	4	1
0	1	0

## Apply convolutions on images

The thing we convolve by is called a **kernel**, or **filter**.

What does this convolution kernel do?



\*

0	1	0
1	4	1
0	1	0



Answer: Blur

Note: We call the resulted image as an "activation map" by the kernel.



## Apply convolutions on images

What does this convolution kernel do?



\*

0	-1	0
-1	8	-1
0	-1	0

## Apply convolutions on images

What does this convolution kernel do?



\*

0	-1	0
-1	8	-1
0	-1	0



Answer: Sharpen

Note: We call the resulted image as an "activation map" by the kernel.

## Apply convolutions on images

What does this convolution kernel do?



\*

0	-1	0
-1	4	-1
0	-1	0

## Apply convolutions on images

What does this convolution kernel do?



\*

0	-1	0
-1	4	-1
0	-1	0



Answer: Edge Detection

Note: We call the resulted image as an "activation map" by the kernel.

## Apply convolutions on images

What does this convolution kernel do?



\*

1	0	-1
2	0	-2
1	0	-1

## Apply convolutions on images

What does this convolution kernel do?



\*

1	0	-1
2	0	-2
1	0	-1



Answer: "Stronger" Edge Detection

Note: We call the resulted image as an "activation map" by the kernel.

## A new layer: Convolution Layers

Fully connected layers:

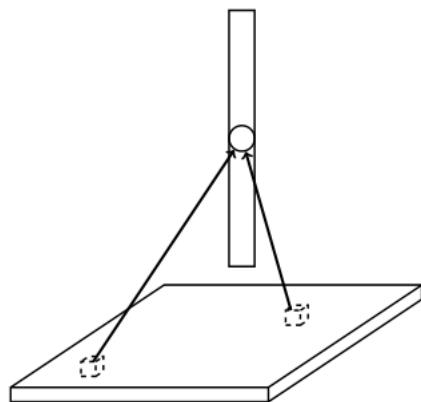
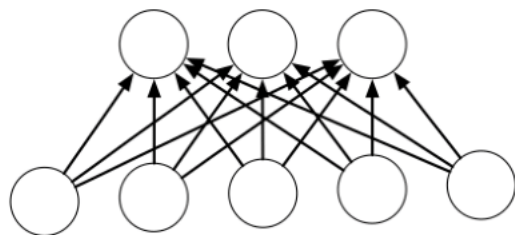

Each hidden unit looks at the entire image.

# A new layer: Convolution Layers

Locally connected layers:

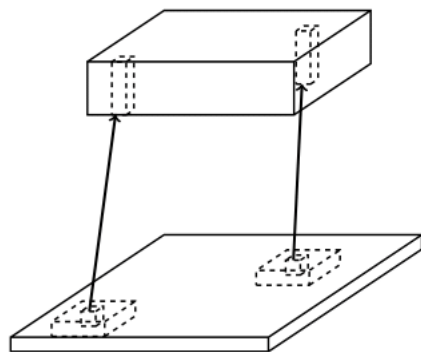
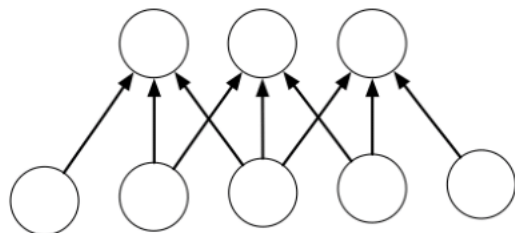

Each column of hidden units looks at a small region of the image.



# A new layer: Convolution Layers

Convolution layers:

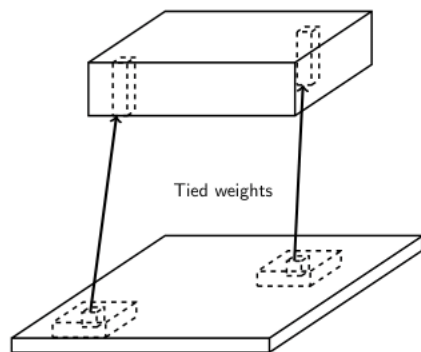
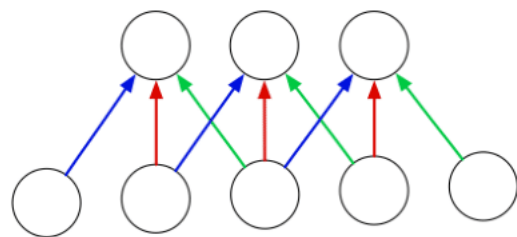

Each column of hidden units looks at a small region of the image, and the weights are shared between all image locations.

## Example Time: A closer look at convolution

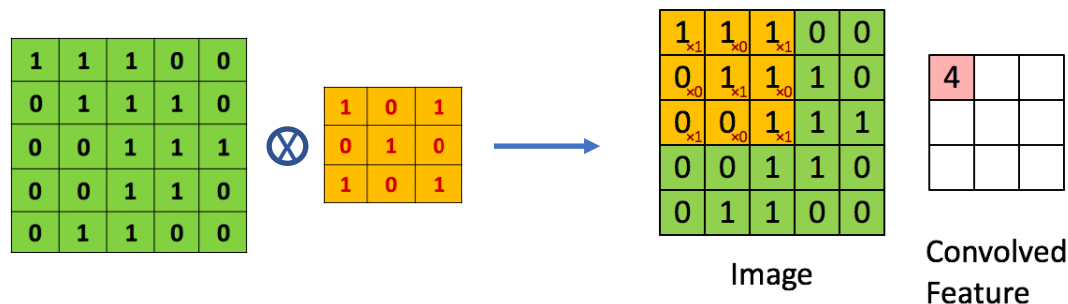

Input: 5 x 5

Output: 3x 3

Kernel: 3 x 3

$$3 = (5 - 3) + 1$$

## Example Time: A closer look at convolution with padding

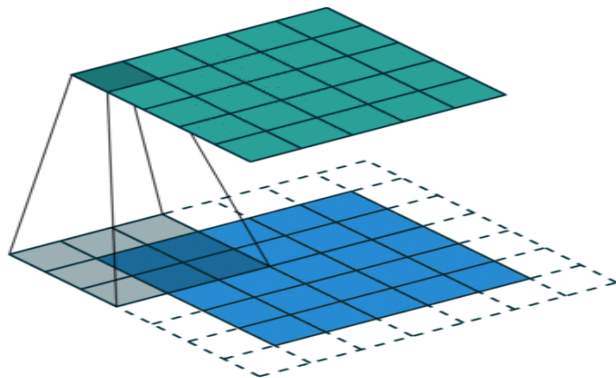

Input: 5 x 5

Output: 5 x 5

Kernel: 3 x 3

Padding: 1

$$5 = (5 - 3 + 2 * 1) + 1$$

## Example Time: A closer look at convolution with stride

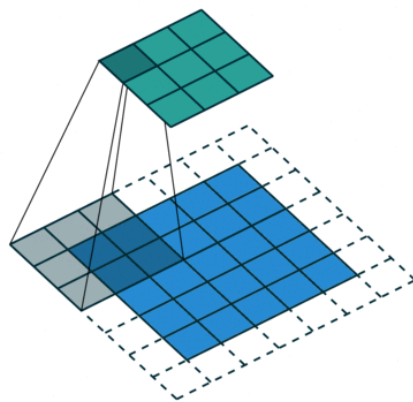

Input: 5 x 5  
Kernel: 3 x 3  
Padding: 1  
Stride = 2

Output: 3 x 3

$$3 = (5 - 3 + 2 * 1) / 2 + 1$$

## A closer look at convolution with high dimensional inputs

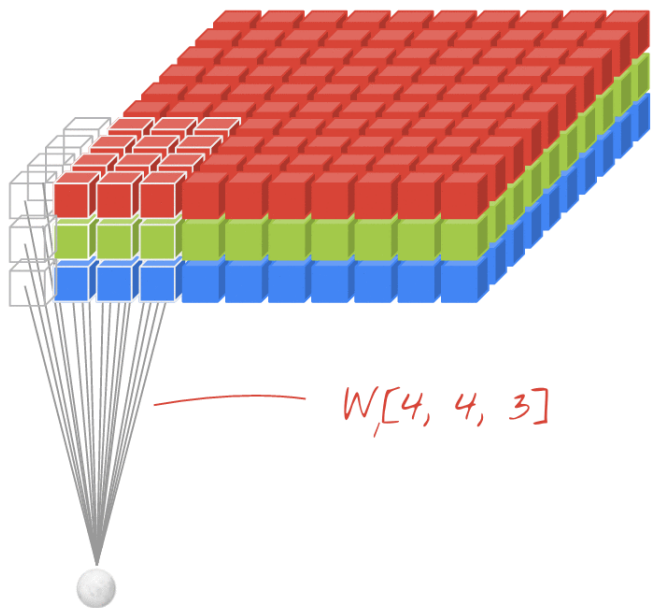

$W[4, 4, 3]$

**Note: Kernel depth always equals to the input depth.**

## Summary : Convolution Layer

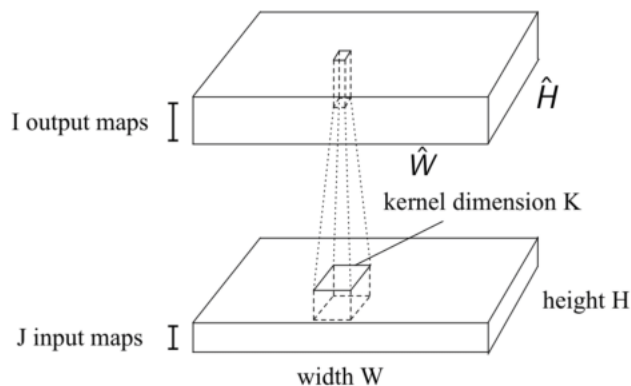

- Input: An array of size  $W \times H \times J$
- Hyper-parameters:
  - Number of filters: M
  - Size of filters: K
  - the stride: S
  - Number of zero-padding: P
- Output: Feature maps of size  $\hat{W} \times \hat{H} \times I$ 
  - $\hat{W} = (W - K + 2P)/S + 1$
  - $\hat{H} = (H - K + 2P)/S + 1$
  - $I = M$

## Let's do some counting: Size of a Conv Net

- Ways to measure the size of a network:
  - **Number of units.** This is important because the activations need to be stored in memory during training (i.e. backprop).
  - **Number of weights.** This is important because the weights need to be stored in memory, and because the number of parameters determines the amount of overfitting.
  - **Number of connections.** This is important because there are approximately 3 add-multiply operations per connection (1 for the forward pass, 2 for the backward pass).
- We saw that a fully connected layer with  $M$  input units and  $N$  output units has  $MN$  connections and  $MN$  weights.
- The story for conv nets is more complicated.

# Let's do some counting: Size of a Conv Net

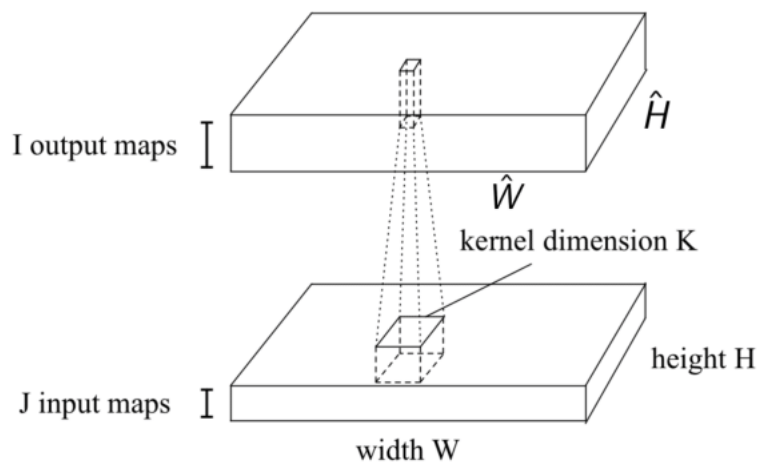

	fully connected layer	convolution layer
# output units	$\hat{W}\hat{H}I$	$\hat{W}\hat{H}I$
# weights	$W\hat{W}H\hat{H}IJ$	$K^2IJ$
# connections	$W\hat{W}H\hat{H}IJ$	$\hat{W}\hat{H}K^2IJ$



# Let's do some counting: Size of a Conv Net (Including bias terms)

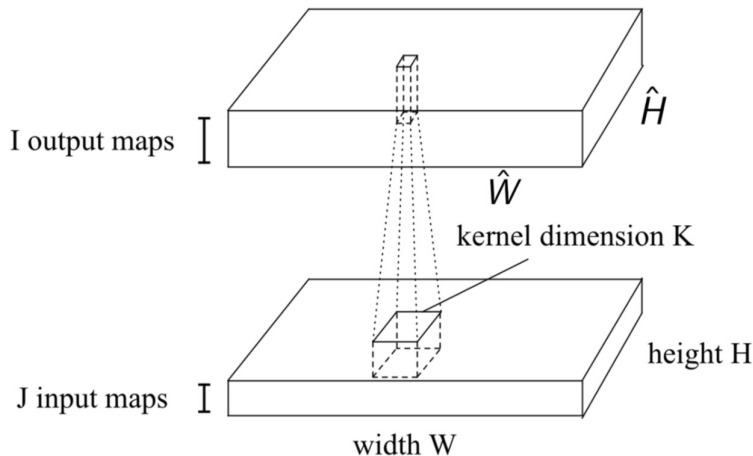

	fully connected layer	convolution layer
# output units	$\hat{W}\hat{H}I$	$\hat{W}\hat{H}I$
# weights	$W\hat{W}H\hat{H}IJ + \hat{W}\hat{H}I$	$K^2IJ + I$
# connections	$W\hat{W}H\hat{H}IJ + \hat{W}\hat{H}I$	$\hat{W}\hat{H}K^2IJ + \hat{W}\hat{H}I$

# Going Deeply Convolutional

Convolution layers can be stacked:

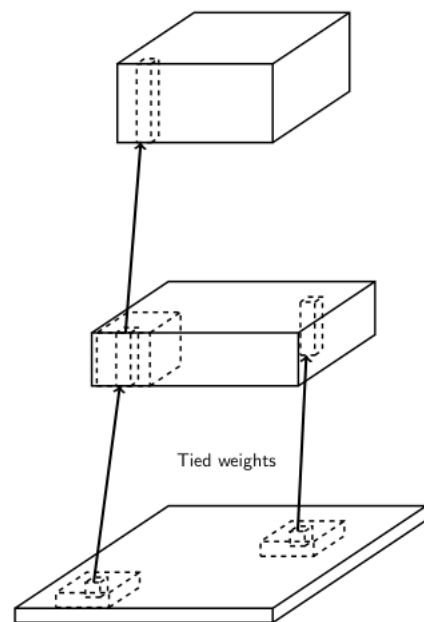

## Pooling layers

The other type of layer in a **pooling layer**. These layers reduce the size of the representation and build in invariance to small transformations.

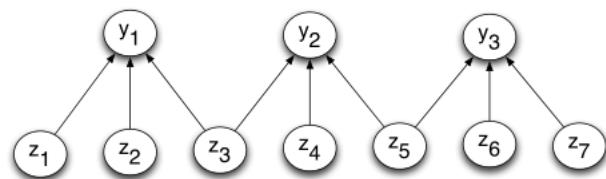

Most commonly, we use **max-pooling**, which computes the maximum value of the units in a **pooling group**:

$$y_i = \max_{j \text{ in pooling group}} z_j$$

# Pooling Layer

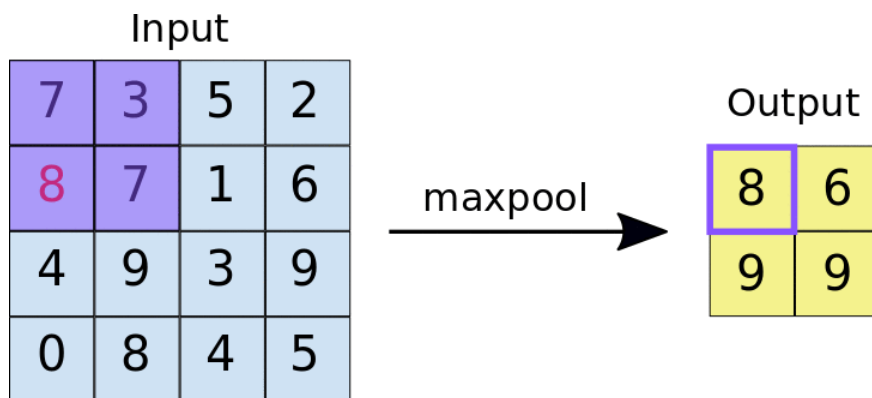

Input: 4 x 4

Kernel: 2 x 2

Stride: 2

Output: 2 x 2

$$2 = (4 - 2) / 2 + 1$$

## Summary : Pooling Layer

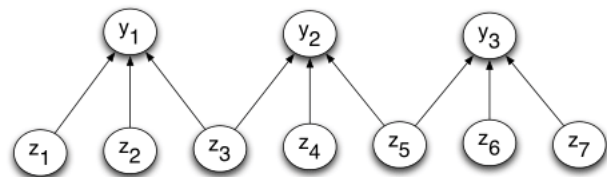

- Input: An array of size  $W \times H \times J$
- Hyper-parameters:
  - Size of filters:  $K$
  - the stride:  $S$
- Output: Feature maps of size  $\hat{W} \times \hat{H} \times I$ 
  - $\hat{W} = (W - K)/S + 1$
  - $\hat{H} = (H - K)/S + 1$
  - $I = J$

Common Setting:  $K = 2, S = 2$

# Convolutional networks

Let's finally turn to convolutional networks. These have two kinds of layers: **detection layers** (or **convolution layers**), and **pooling layers**. The convolution layer has a set of filters. Its output is a set of **feature maps**, each one obtained by convolving the image with a filter.

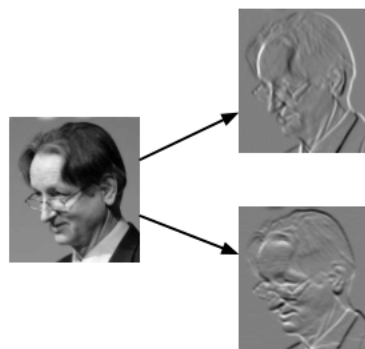

convolution

# Convolutional networks

Let's finally turn to convolutional networks. These have two kinds of layers: **detection layers** (or **convolution layers**), and **pooling layers**. The convolution layer has a set of filters. Its output is a set of **feature maps**, each one obtained by convolving the image with a filter.

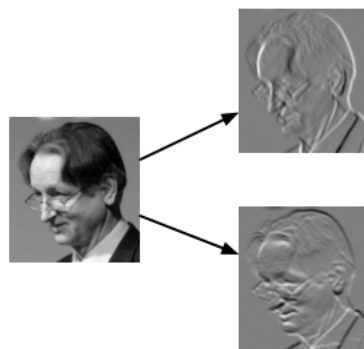

convolution

## Example first-layer filters

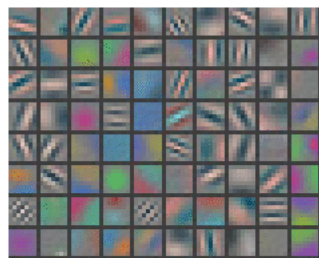

(Zeiler and Fergus, 2013,

Visualizing and understanding convolutional networks)

# Convolutional networks

It's common to apply a linear rectification nonlinearity:  $y_i = \max(z_i, 0)$

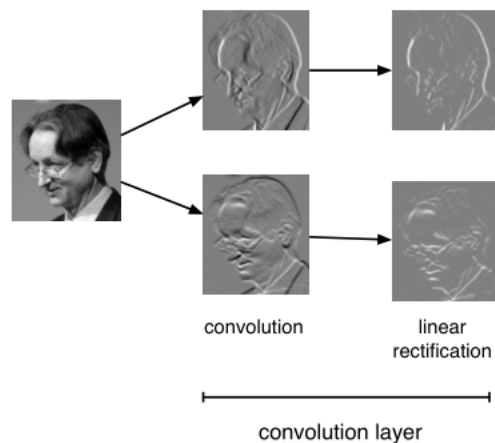

Why might we do this?



# Convolutional networks

It's common to apply a linear rectification nonlinearity:  $y_i = \max(z_i, 0)$

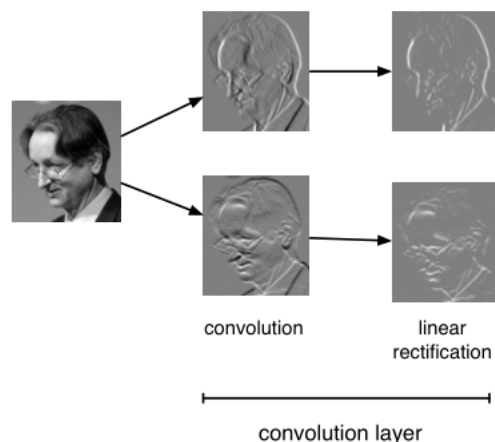

Why might we do this?

- Convolution is a linear operation. Therefore, we need a nonlinearity, otherwise 2 convolution layers would be no more powerful than 1.
- Two edges in opposite directions shouldn't cancel

# Convolutional networks

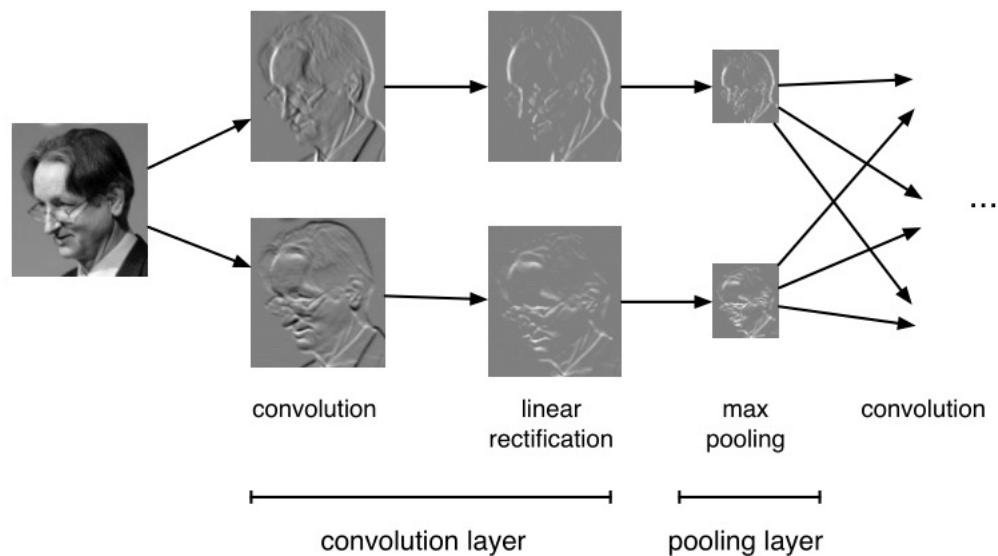

# Convolutional networks

Because of pooling, higher-layer filters can cover a larger region of the input than equal-sized filters in the lower layers.

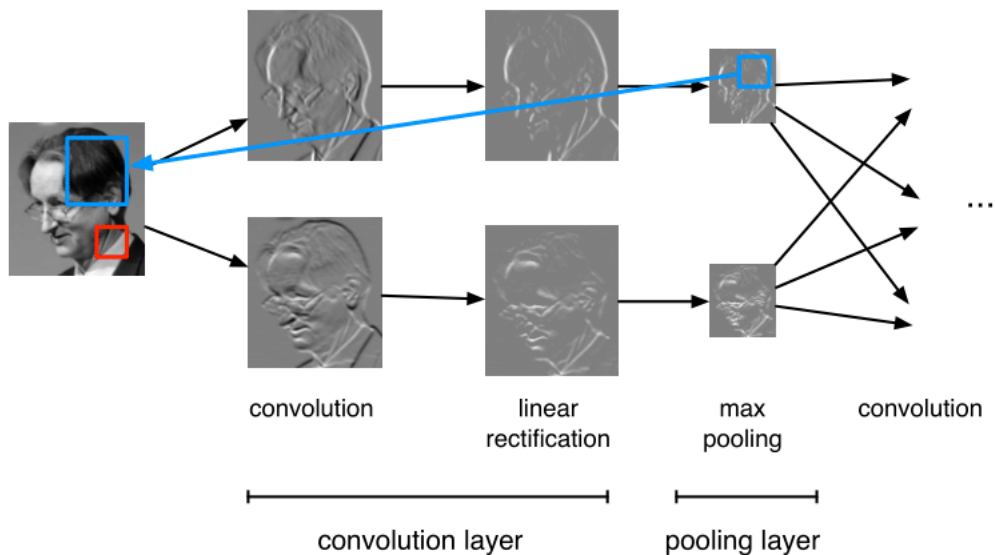

# Equivariance and Invariance

We said the network's responses should be robust to translations of the input. But this can mean two different things.

- Convolution layers are **equivariant**: if you translate the inputs, the outputs are translated by the same amount.
- We'd like the network's predictions to be **invariant**: if you translate the inputs, the prediction should not change.
- Pooling layers provide invariance to small translations.

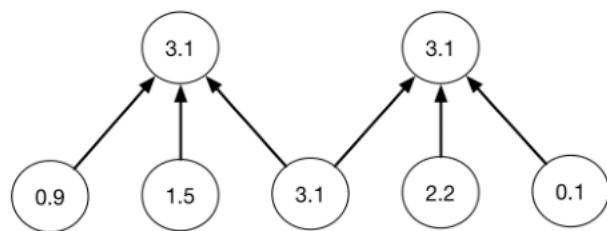
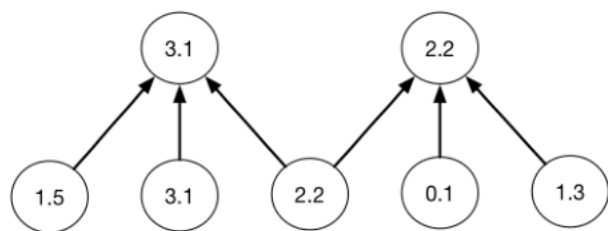

## Backprop Updates (Optional)

How do we train a conv net? With backprop, of course!

Recall what we need to do. Backprop is a message passing procedure, where each layer knows how to pass messages backwards through the computation graph. Let's determine the updates for convolution layers.

- We assume we are given the loss derivatives  $\overline{y_{i,t}}$  with respect to the output units.
- We need to compute the cost derivatives with respect to the input units and with respect to the weights.

The only new feature is: how do we do backprop with tied weights?

## Backprop Updates (Optional)

Consider the computation graph for the inputs:

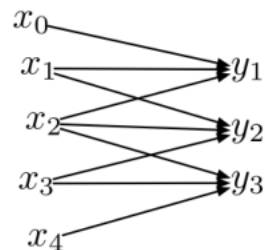
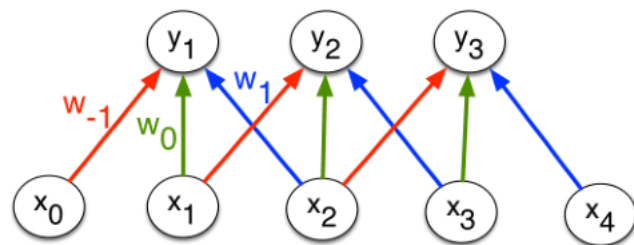

Each input unit influences all the output units that have it within their receptive fields. Using the multivariate Chain Rule, we need to sum together the derivative terms for all these edges.

## Backprop Updates (Optional)

Recall the formula for the convolution layer:

$$y_{i,t} = \sum_{j=1}^J \sum_{\tau=-R}^R w_{i,j,\tau} x_{j,t+\tau}.$$

We compute the derivatives, which requires summing over all the outputs units which have the input unit in their receptive field:

$$\begin{aligned} \overline{x_{j,t}} &= \sum_{\tau} \overline{y_{i,t-\tau}} \frac{\partial y_{i,t-\tau}}{\partial x_{j,t}} \\ &= \sum_{\tau} \overline{y_{i,t-\tau}} w_{i,j,\tau} \end{aligned}$$

Written in terms of convolution,

$$\overline{\mathbf{x}}_j = \overline{\mathbf{y}}_i * \mathbf{w}_{i,j}.$$

## Backprop Updates (Optional)

Consider the computation graph for the weights:

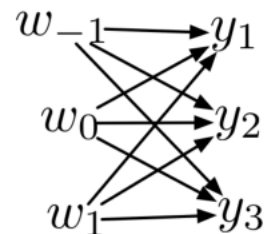
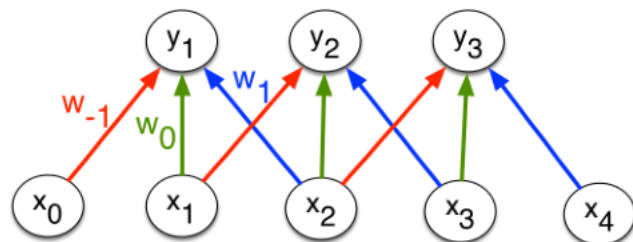

Each of the weights affects all the output units for the corresponding input and output feature maps.



## Backprop Updates (Optional)

Recall the formula for the convolution layer:

$$y_{i,t} = \sum_{j=1}^J \sum_{\tau=-R}^R w_{i,j,\tau} x_{j,t+\tau}.$$

We compute the derivatives, which requires summing over all spatial locations:

$$\begin{aligned} \overline{w_{i,j,\tau}} &= \sum_t \overline{y_{i,t}} \frac{\partial y_{i,t}}{\partial w_{i,j,\tau}} \\ &= \sum_t \overline{y_{i,t}} x_{j,t+\tau} \end{aligned}$$

## After the break

After the break: **Object Recognition using CNN!**

# Object recognition

- Object recognition is the task of identifying which object category is present in an image.
- It's challenging because objects can differ widely in position, size, shape, appearance, etc., and we have to deal with occlusions, lighting changes, etc.
- Why we care about it
  - Direct applications to image search
  - Closely related to **object detection**, the task of locating all instances of an object in an image
    - E.g., a self-driving car detecting pedestrians or stop signs
- For the past 6 years, all of the best object recognizers have been various kinds of conv nets.

# Datasets

- In order to train and evaluate a machine learning system, we need to collect a dataset. The design of the dataset can have major implications.
- Some questions to consider:
  - Which categories to include?
  - Where should the images come from?
  - How many images to collect?
  - How to normalize (preprocess) the images?

# Image Classification

- Conv nets are just one of many possible approaches to image classification. However, they have been by far the most successful for the last 8 years.
- Biggest image classification “advances” of the last two decades
  - Datasets have gotten much larger (because of digital cameras and the Internet)
  - Computers got much faster
    - Graphics processing units (GPUs) turned out to be really good at training big neural nets; they’re generally about 30 times faster than CPUs.
  - As a result, we could fit bigger and bigger neural nets.

# MNIST Dataset

- MNIST dataset of handwritten digits
  - **Categories:** 10 digit classes
  - **Source:** Scans of handwritten zip codes from envelopes
  - **Size:** 60,000 training images and 10,000 test images, grayscale, of size  $28 \times 28$
  - **Normalization:** centered within in the image, scaled to a consistent size
    - The assumption is that the digit recognizer would be part of a larger pipeline that segments and normalizes images.
- In 1998, Yann LeCun and colleagues built a conv net called **LeNet** which was able to classify digits with 98.9% test accuracy.
  - It was good enough to be used in a system for automatically reading numbers on checks.

# ImageNet

ImageNet is the modern object recognition benchmark dataset. It was introduced in 2009, and has led to amazing progress in object recognition since then.

ILSVRC



flamingo



cock

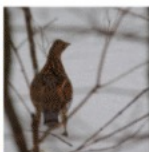

ruffed grouse



quail



partridge

...



Egyptian cat



Persian cat



Siamese cat

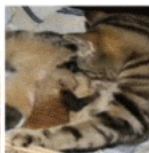

tabby



lynx

...

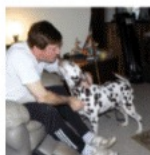

dalmatian



keeshond



miniature schnauzer



standard schnauzer



giant schnauzer

...

# ImageNet

- Used for the ImageNet Large Scale Visual Recognition Challenge (ILSVRC), an annual benchmark competition for object recognition algorithms
- Design decisions
  - **Categories:** Taken from a lexical database called WordNet
    - WordNet consists of “synsets”, or sets of synonymous words
    - They tried to use as many of these as possible; almost 22,000 as of 2010
    - Of these, they chose the 1000 most common for the ILSVRC
    - The categories are really specific, e.g. hundreds of kinds of dogs
  - **Size:** 1.2 million full-sized images for the ILSVRC
  - **Source:** Results from image search engines, hand-labeled by Mechanical Turkers
    - Labeling such specific categories was challenging; annotators had to be given the WordNet hierarchy, Wikipedia, etc.
  - **Normalization:** none, although the contestants are free to do preprocessing



# ImageNet

Images and object categories vary on a lot of dimensions

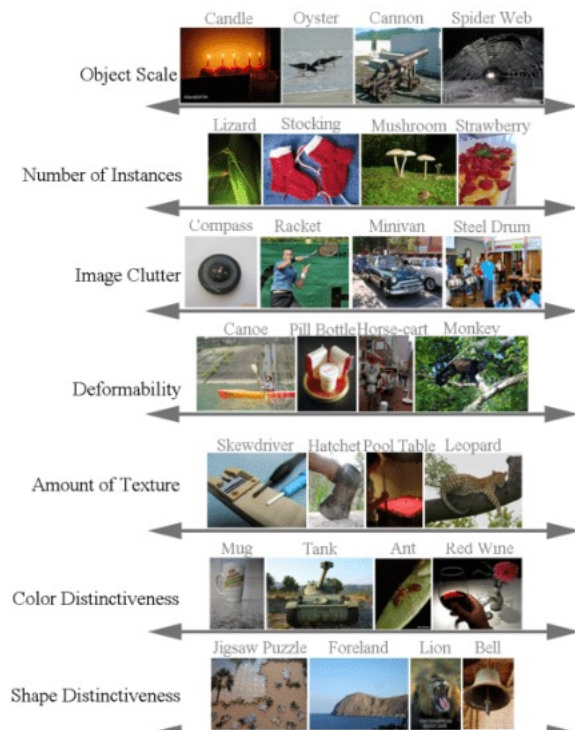

Russakovsky et al.

# ImageNet

Size on disk:

MNIST  
60 MB



ImageNet  
50 GB



# Case Study: LeNet

Here's the LeNet architecture, which was applied to handwritten digit recognition on MNIST in 1998:

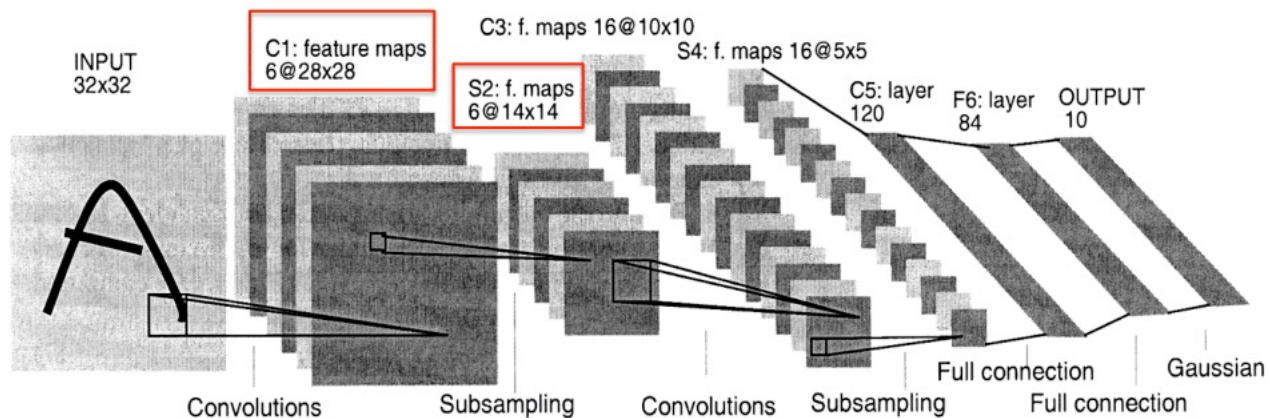

# Size of a Conv Net

Sizes of layers in LeNet:

Layer	Type	# units	# connections	# weights
C1	convolution	4704	117,600	150
S2	pooling	1176	4704	0
C3	convolution	1600	240,000	2400
S4	pooling	400	1600	0
F5	fully connected	120	48,000	48,000
F6	fully connected	84	10,080	10,080
output	fully connected	10	840	840

Conclusions?

# Size of a Conv Net

- Rules of thumb:
  - Most of the units and connections are in the convolution layers.
  - Most of the weights are in the fully connected layers.
- If you try to make layers larger, you'll run up against various resource limitations (i.e. computation time, memory)
- Conv nets have gotten a LOT larger since 1998!

# Case Study: AlexNet

- AlexNet, 2012. 8 weight layers. 16.4% top-5 error (i.e. the network gets 5 tries to guess the right category).

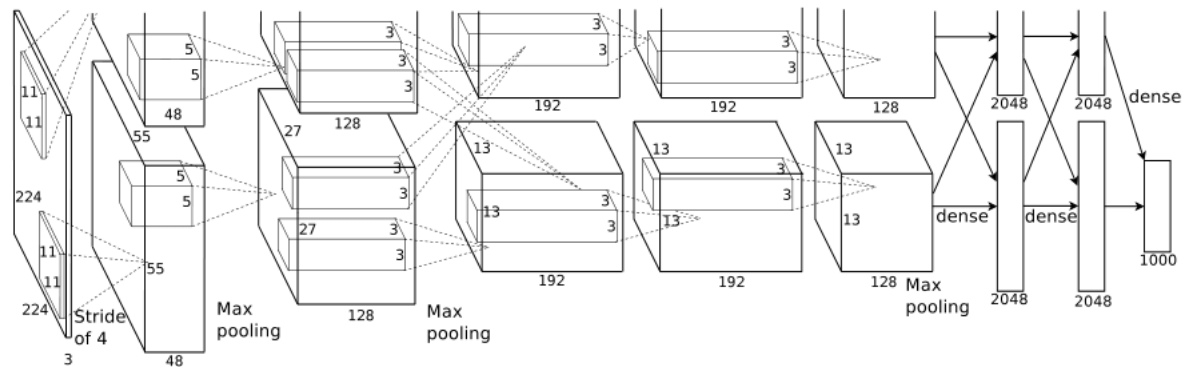

(Krizhevsky et al., 2012)

- They used lots of tricks we've covered in this course (ReLU units, weight decay, data augmentation, SGD with momentum, dropout)
- AlexNet's stunning performance on the ILSVRC is what set off the deep learning boom of the last 6 years.

# Size of a Conv Net

	<b>LeNet (1989)</b>	<b>LeNet (1998)</b>	<b>AlexNet (2012)</b>
<b>classification task</b>	digits	digits	objects
<b>categories</b>	10	10	1,000
<b>image size</b>	$16 \times 16$	$28 \times 28$	$256 \times 256 \times 3$
<b>training examples</b>	7,291	60,000	1.2 million
<b>units</b>	1,256	8,084	658,000
<b>parameters</b>	9,760	60,000	60 million
<b>connections</b>	65,000	344,000	652 million

# GoogLeNet

GoogLeNet, 2014.

22 weight layers

Fully convolutional (no fully connected layers)

Convolutions are broken down into a bunch of smaller convolutions

6.6% test error on ImageNet

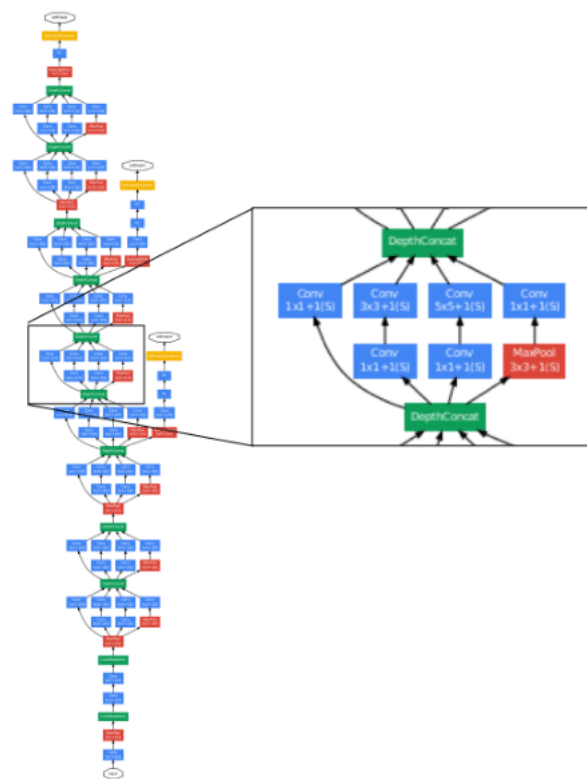



- They were really aggressive about cutting the number of parameters.
  - Motivation: train the network on a large cluster, run it on a cell phone
    - Memory at test time is the big constraint.
    - Having lots of units is OK, since the activations only need to be stored at training time (for backpropagation).
    - Parameters need to be stored both at training and test time, so these are the memory bottleneck.
  - How they did it
    - No fully connected layers (remember, these have most of the weights)
    - Break down convolutions into multiple smaller convolutions (since this requires fewer parameters total)
  - GoogLeNet has “only” 2 million parameters, compared with 60 million for AlexNet
  - This turned out to improve generalization as well. (Overfitting can still be a problem, even with over a million images!)

# Classification --- A brief history of ImageNet Competition

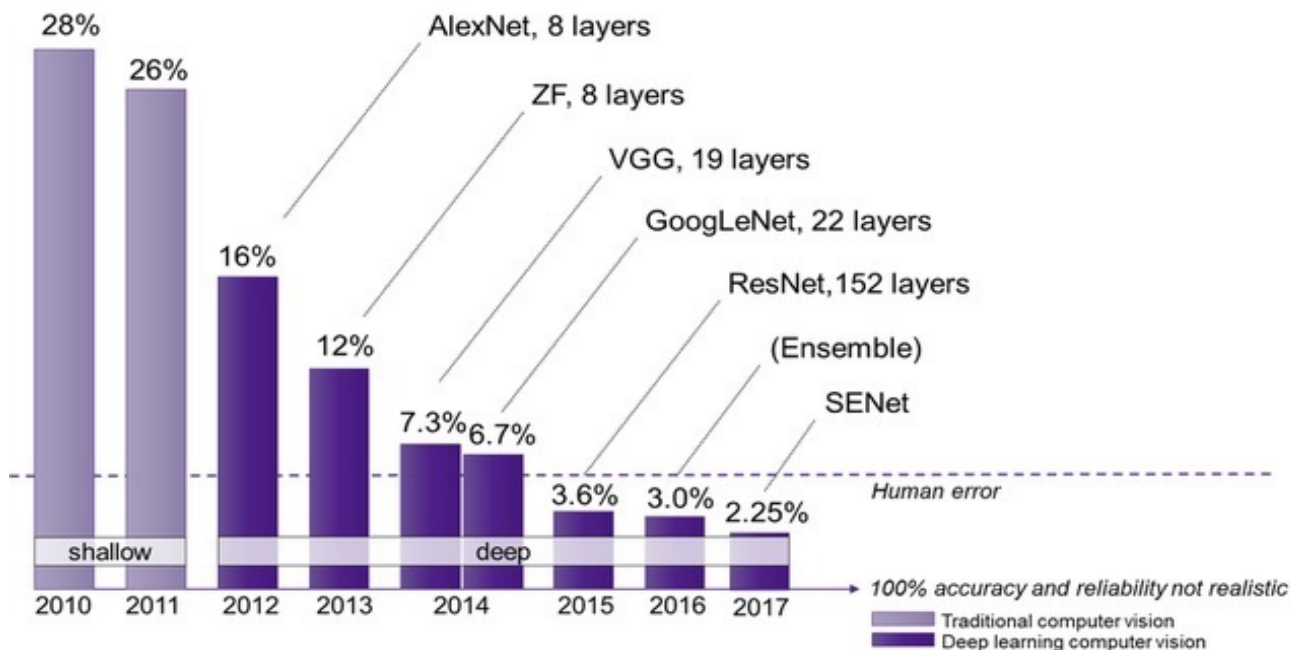

Observation 1: Deep models (mostly CNNs) dominate the task of object recognition.

## Classification --- A brief history of ImageNet Competition

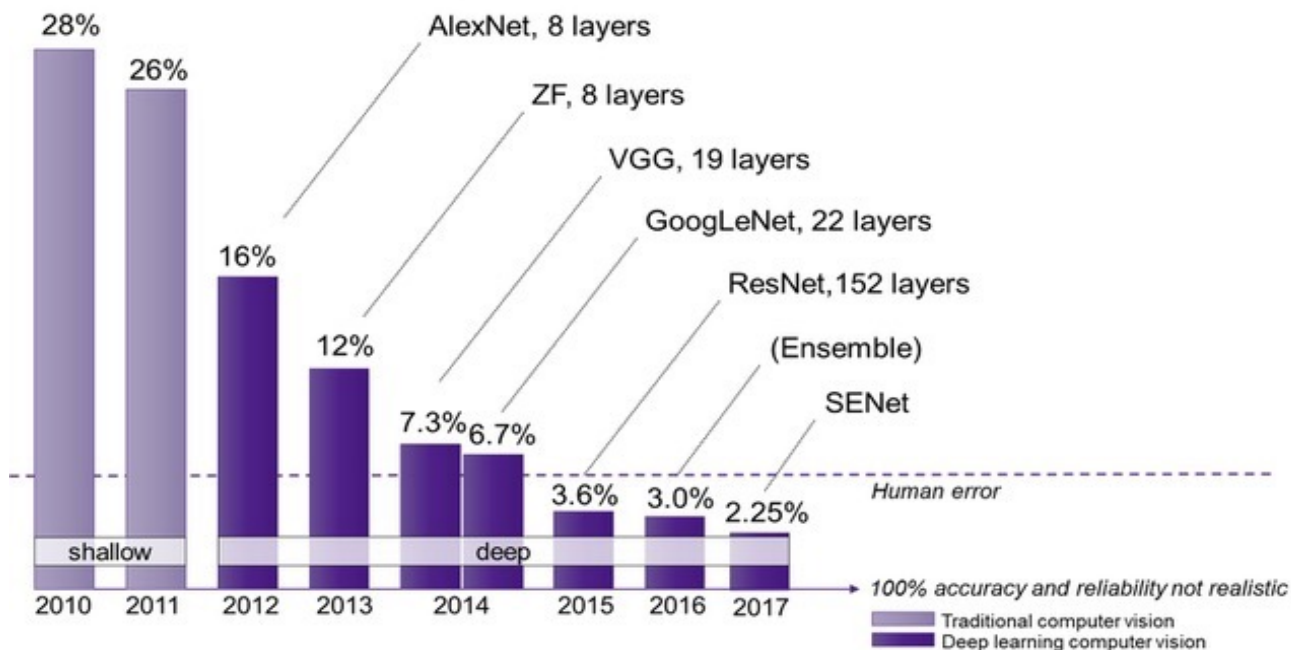

Observation 2: The accuracy by CNNs improves every year and even outperforms human performances.

## Classification --- A brief history of ImageNet Competition

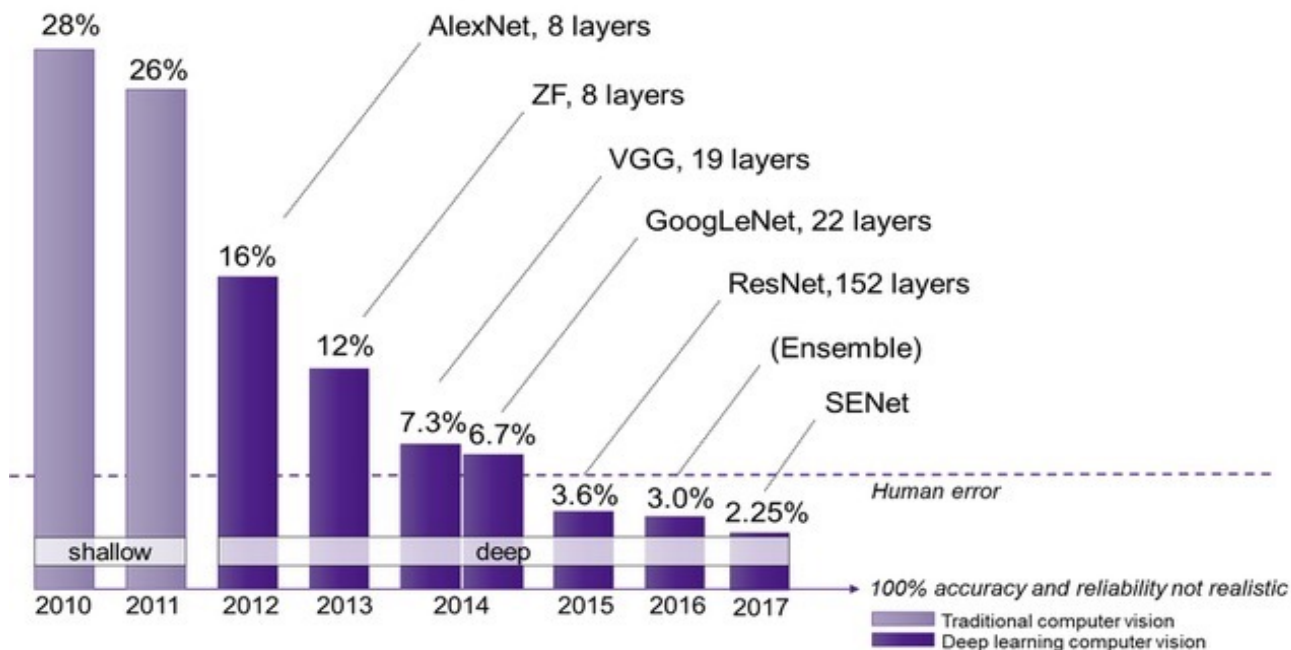

Observation 3: The STOA CNNs are getting deeper and deeper.

## Classification --- A brief history of ImageNet Competition

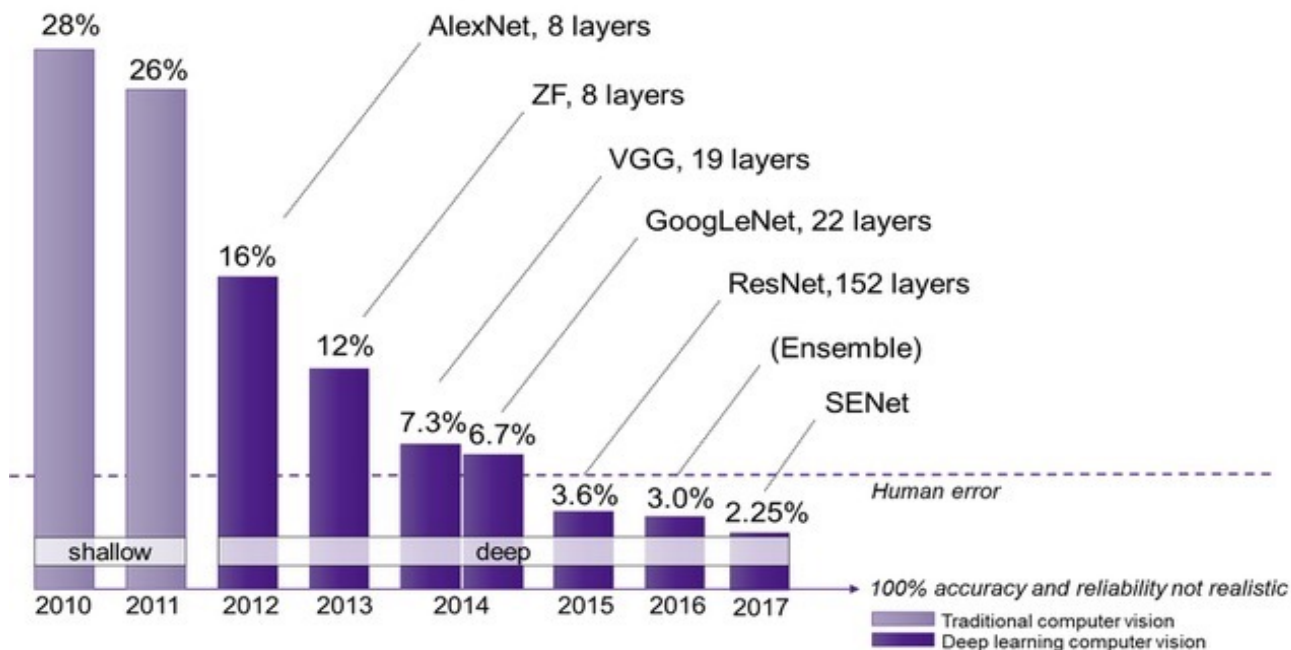

Observation 4: The performance of object recognition is so good that they stopped the competition nowadays.

# Beyond Classification

- The classification nets map the entire input image to a pre-defined class categories.
- But there are more than just class labels in an image.
  - where is the foreground object? how many? what is in the background?

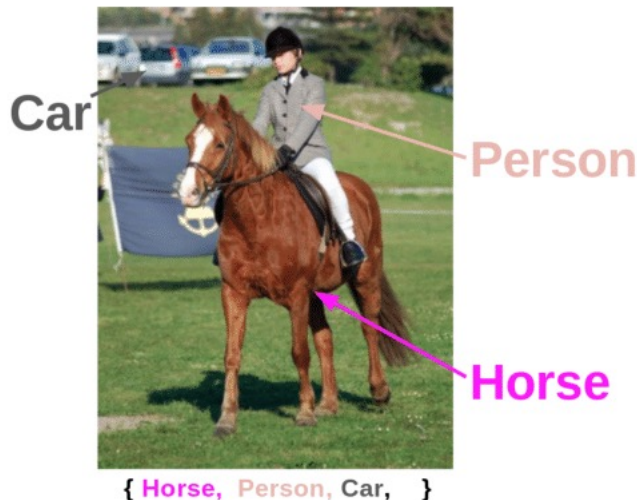

(PASCAL VOC 2012)

# Semantic Segmentation

- Semantic segmentation, a natural extension of classification, focuses on making dense classification of class labels for **every pixel**.
- It is an important step towards complete scene understanding in computer vision.
  - Semantic segmentation is a stepping stone for many of the high-level vision tasks, such as object detection, Visual Question Answering (VQA).
- A naive approach is to adapt the existing object classification conv nets for each pixel. This works surprisingly well

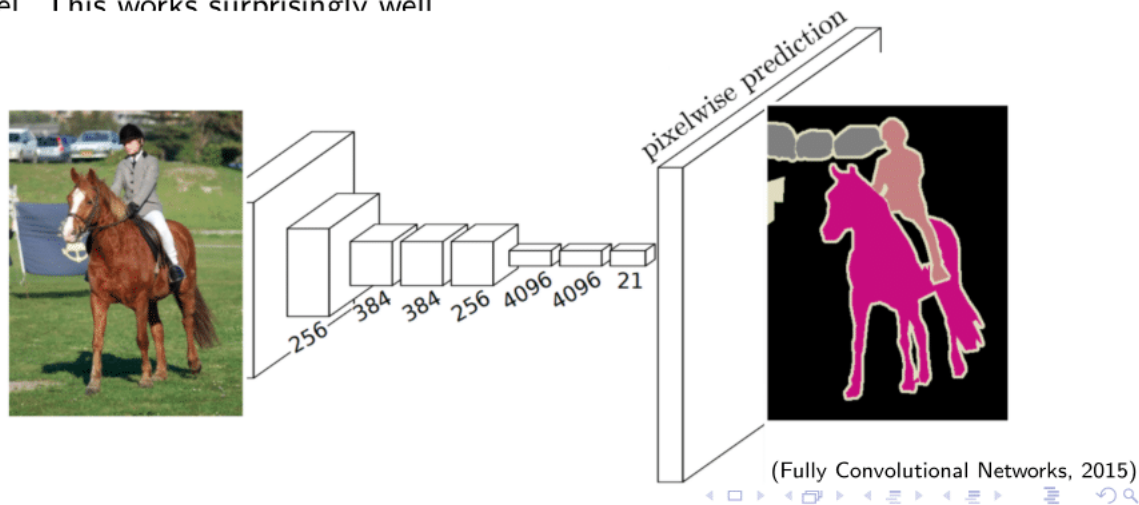

# Semantic Segmentation

- After the success of CNN classifiers, segmentation models quickly moved away from hand-craft features and pipelines but instead use CNN as the main structure.
- Pre-trained ImageNet classification network serves as a building block for all the state-of-the-art CNN-based segmentation models.

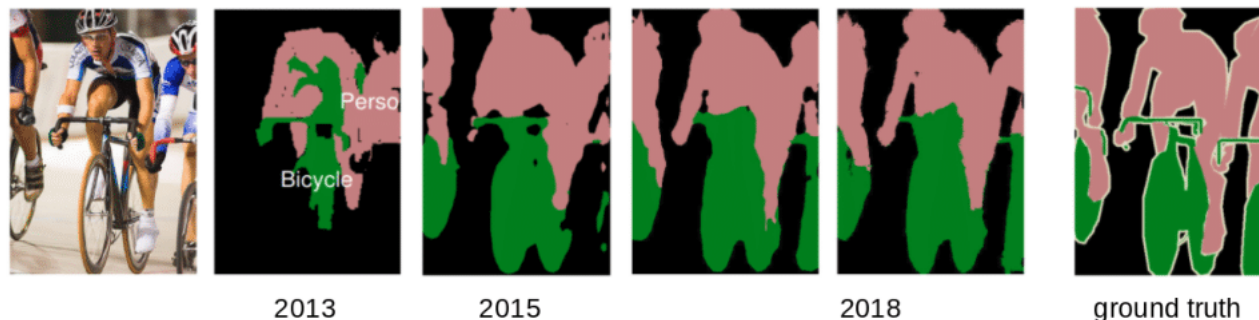

from left to right (Li, et. al., (CSI), CVPR, 2013; Long, et. al., (FCN), CVPR 2015; Chen et. al., (DeepLab), PAMI 2018)



# CNN on HealthCare

- CNN has also been widely used in processing medical images.
- Pre-trained ImageNet classification network serves as a building block for most of medical image segmentation/classification models.

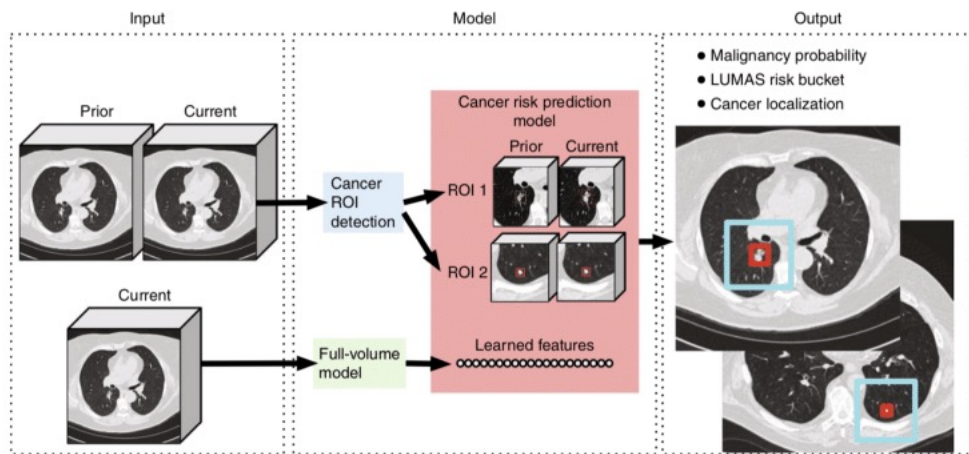

from: google AI: End-to-end lung cancer screening with three-dimensional deep learning on low-dose chest computed tomography. Nature medicine, 2019.

# Supervised Pre-training and Transfer Learning

- In practice, we will rarely train an image classifier from scratch.
  - It is unlikely we will have millions of cleanly labeled images for our specific datasets.
- If the dataset is a computer vision task, it is common to fine-tune a pre-trained conv net on ImageNet or OpenImage.
- Just like semantic segmentation tasks, we will fix most of the weights in the pre-trained network. Only the weights in the last layer will be randomly initialized and learnt on the current dataset/task.

# Transfer Learning : Fine-Tuning

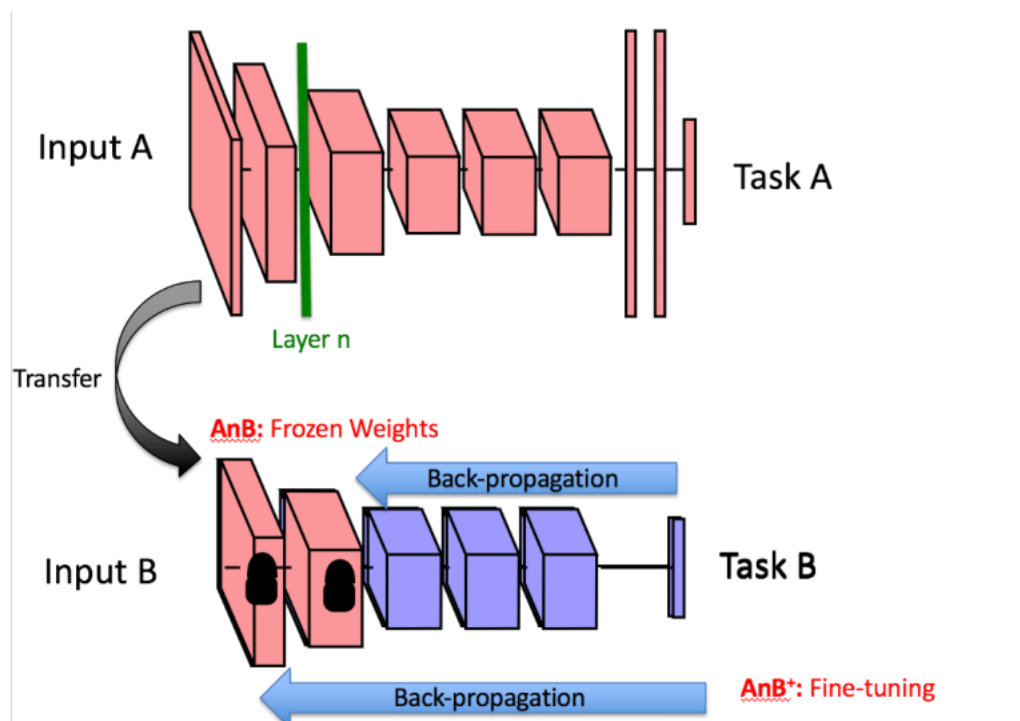

# Supervised Pre-training and Transfer Learning

- When to fine-tune?
  - How many training examples we have in the new dataset/task?
    - Fewer new examples: more weights from the pre-trained networks are fixed.
  - How similar is the new dataset to our pre-training dataset? Microspy images v.s. natural images:
    - more fine-tuning is needed for dissimilar datasets.
  - Learning rate for the fine-tuning stage is often much lower than the learning rate used for training from scratch.

## Closing Thoughts

1. Convolutional Layers are the building blocks of computer vision applications (e.g., object recognition/detection/segmentation)!
2. Convolutional Layers use tied weights and obtain translation invariance.
3. CNNs (or its variants) are the go-to methods for many image-related applications.
4. CNNs can be also interpreted as a *feature/representation learning* method for images.
5. Transfer learning by fine-tuning is often used in training CNNs.
6. How to best train CNNs? Stay tuned for Lecture 6 with bags of tricks!